

Cree® XLamp® CXB2540 LED



PRODUCT DESCRIPTION

The XLamp® CXB2540 LED Array is a member of the second generation of the CXA family that delivers up to 30% higher efficacy and up to 20% higher lumens than the first generation in the same LES. The higher performance second generation CXA LED Arrays provide a drop-in performance upgrade to existing CXA LED designs to shorten product development time. In addition, the CXB LEDs also allow lighting manufacturers to achieve the same or better performance with a smaller LES, enabling a smaller, more impactful luminaire. Available in 2-step, 3-step and 5-step EasyWhite® bins, the CXB2540 LED delivers high lumen output and high efficacy in a single, easy-to-use package that eliminates the need for reflow soldering.

The [CX Family LED Design Guide](#) provides basic information on the requirements to use the CXB2540 LED successfully in luminaire designs.

FEATURES

- 19-mm optical source
- Mechanical and optical design consistent with other CXA25 and CXB25 LEDs
- Available in 70-, 80- and 90-minimum CRI options
- Cree EasyWhite® 2-, 3- and 5-step binning
- Forward voltage option: 36-V class
- 85 °C binning and characterization
- Extremely uniform color over viewing angle
- Top-side solder connections
- Thermocouple attach point
- NEMA SSL-3 2011 standard flux bins
- RoHS and REACH compliant
- UL® recognized component (E349212)

TABLE OF CONTENTS

Characteristics	2
Operating Limits.....	2
Flux Characteristics, EasyWhite® Order Codes and Bins	3
Relative Spectral Power Distribution	5
Electrical Characteristics.....	6
Relative Luminous Flux.....	7
Typical Spatial Distribution.....	8
Performance Groups - Brightness	8
Performance Groups - Chromaticity.....	9
Cree's EasyWhite® Bins Plotted on the 1931 CIE Color Space	10
Bin and Order Code Formats.....	12
Mechanical Dimensions	12
Thermal Design.....	13
Notes	14
Packaging.....	15



CHARACTERISTICS

Characteristics	Unit	Minimum	Typical	Maximum
Viewing angle (FWHM)	degrees		115	
ESD withstand voltage (HBM per Mil-Std-883D)	V			8000
DC forward current	mA			2100*
Reverse current	mA			0.1
Forward voltage (@ 1100 mA, T _j = 85 °C)	V		34.8	38

* Refer to the Operating Limits section.

OPERATING LIMITS

The maximum current rating of the CXB2540 is dependent on the case temperature (T_c) when the LED has reached thermal equilibrium under steady-state operation. The graph shown below assumes that the system design employs good thermal management (thermal interface material and heat sink) and may vary when poor thermal management is employed. Please refer to the Mechanical Dimensions section on page 12 for the location of the T_c measurement point.

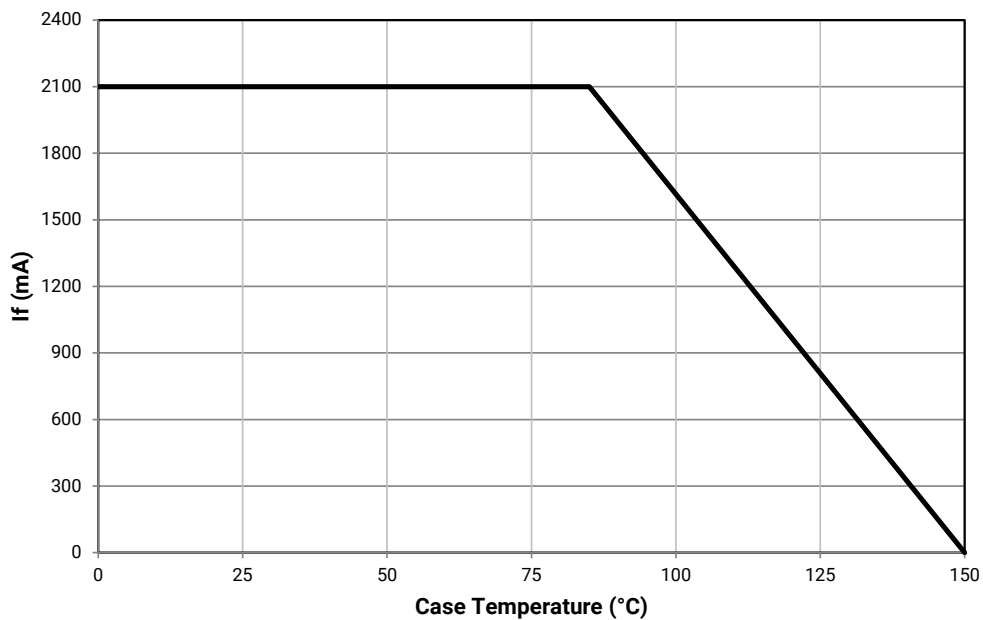

FLUX CHARACTERISTICS, EASYWHITE® ORDER CODES AND BINS (I_F = 1100 mA, T_J = 85 °C)

The following table provides order codes for XLamp CXB2540 LEDs. For a complete description of the order code nomenclature, please see the Bin and Order Code Formats section (page 12).

Nominal CCT	CRI*		Minimum Luminous Flux			2-Step		3-Step				5-Step	
	Min	Typ	Group	Flux (lm) @ 85 °C	Flux (lm) @ 25 °C**	Group	Order Code	Group	Order Code	Group	Order Code	Group	Order Code
6500 K	70	---	W4	5225	5784							65E	CXB2540-0000-000N0BW465E
			X2	5590	6188								CXB2540-0000-000N0BX265E
	80	---	W4	5225	5784							65E	CXB2540-0000-000N0HW465E
			X2	5590	6188								CXB2540-0000-000N0HX265E
5700 K	70	---	W4	5225	5784							57E	CXB2540-0000-000N0BW457E
			X2	5590	6188								CXB2540-0000-000N0BX257E
	80	---	W4	5225	5784							57E	CXB2540-0000-000N0HW457E
			X2	5590	6188								CXB2540-0000-000N0HX257E
5000 K	70	---	W4	5225	5784							50E	CXB2540-0000-000N0BW450E
			X2	5590	6188								CXB2540-0000-000N0BX250E
	80	---	W4	5225	5784			50G	CXB2540-0000-000N0HW450G			50E	CXB2540-0000-000N0HW450E
			X2	5590	6188								CXB2540-0000-000N0HX250E
	90	92	V4	4545	5031			50G	CXB2540-0000-000N0UV450G				
			W2	4860	5380								
4000 K	70	---	W4	5225	5784							40E	CXB2540-0000-000N0BW440E
			X2	5590	6188								CXB2540-0000-000N0BX240E
	80	---	W2	4860	5380	40H	CXB2540-0000-000N0HW240H	40G	CXB2540-0000-000N0HW240G				
			W4	5225	5784		CXB2540-0000-000N0HW440H		CXB2540-0000-000N0HW440G				
	90	92	V2	4230	4683	40H	CXB2540-0000-000N0UV240H	40G	CXB2540-0000-000N0UV240G				
			V4	4545	5031		CXB2540-0000-000N0UV440H		CXB2540-0000-000N0UV440G				

- Notes**
- Cree maintains a tolerance of ±7% on flux and power measurements, ±0.005 on chromaticity (CCx, CCy) measurements and a tolerance of ±2 on CRI measurements. See the Measurements section (page 14).
 - Cree XLamp CXB2540 LED order codes specify only a minimum flux bin and not a maximum. Cree may ship reels in flux bins higher than the minimum specified by the order code without advance notice. Shipments will always adhere to the chromaticity bin restrictions specified by the order code.
 - * For 80 CRI minimum LEDs, CRI R9 minimum is 0 with a ±2 tolerance. For 90 CRI minimum LEDs, CRI R9 typical is 60.
 - ** Flux values @ 25 °C are calculated and for reference only.

FLUX CHARACTERISTICS, EASYWHITE® ORDER CODES AND BINS (I_F = 1100 mA, T_J = 85 °C) - CONTINUED

Nominal CCT	CRI*		Minimum Luminous Flux			2-Step		3-Step				5-Step		
	Min	Typ	Group	Flux (lm) @ 85 °C	Flux (lm) @ 25 °C**	Group	Order Code	Group	Order Code	Group	Order Code	Group	Order Code	
3500 K	80	---	W2	4860	5380	35H	CXB2540-0000-000N0HW235H	35G	CXB2540-0000-000N0HW235G					
			W4	5225	5784		CXB2540-0000-000N0HW435H		CXB2540-0000-000N0HW435G					
	90	92	V2	4230	4683	35H	CXB2540-0000-000N0UV235H	35G	CXB2540-0000-000N0UV235G					
			V4	4545	5031		CXB2540-0000-000N0UV435H		CXB2540-0000-000N0UV435G					
3000 K	80	---	V4	4545	5031	30H	CXB2540-0000-000N0HV430H	30G	CXB2540-0000-000N0HV430G					
			W2	4860	5380		CXB2540-0000-000N0HW230H		CXB2540-0000-000N0HW230G					
	90	92	U4	3955	4378	30H	CXB2540-0000-000N0UU430H	30G	CXB2540-0000-000N0UU430G					
			V2	4230	4683		CXB2540-0000-000N0UV230H		CXB2540-0000-000N0UV230G					
	90	92	U2	3680	4074			30Q		30U	CXB2540-0000-000N0UU230U			
			U4	3955	4378						CXB2540-0000-000N0UU430Q			
			V2	4230	4683					CXB2540-0000-000N0UV230Q				
2700 K	80	---	V4	4545	5031	27H	CXB2540-0000-000N0HV427H	27G	CXB2540-0000-000N0HV427G					
			W2	4860	5380		CXB2540-0000-000N0HW227H		CXB2540-0000-000N0HW227G					
	90	92	U2	3680	4074	27H	CXB2540-0000-000N0UU227H	27G	CXB2540-0000-000N0UU227G					
			U4	3955	4378		CXB2540-0000-000N0UU427H		CXB2540-0000-000N0UU427G					

- Notes**
- Cree maintains a tolerance of ±7% on flux and power measurements, ±0.005 on chromaticity (CCx, CCy) measurements and a tolerance of ±2 on CRI measurements. See the Measurements section (page 14).
 - Cree XLamp CXB2540 LED order codes specify only a minimum flux bin and not a maximum. Cree may ship reels in flux bins higher than the minimum specified by the order code without advance notice. Shipments will always adhere to the chromaticity bin restrictions specified by the order code.
 - * For 80 CRI minimum LEDs, CRI R9 minimum is 0 with a ±2 tolerance. For 90 CRI minimum LEDs, CRI R9 typical is 60.
 - ** Flux values @ 25 °C are calculated and for reference only.

RELATIVE SPECTRAL POWER DISTRIBUTION

The following graph is the result of a series of pulsed measurements at 1100 mA and $T_j = 85^\circ\text{C}$.

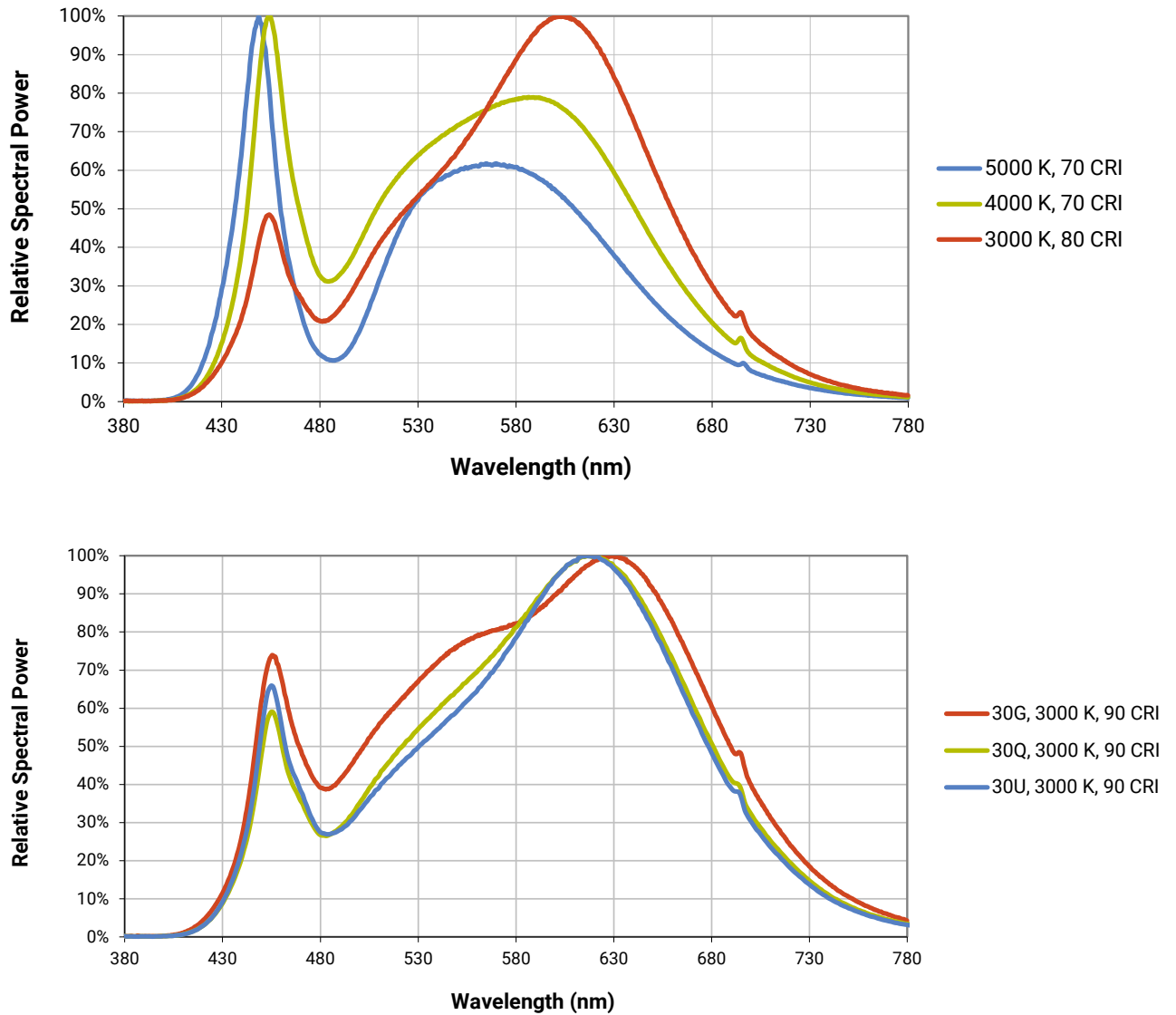

ELECTRICAL CHARACTERISTICS

The following graph is the result of a series of steady-state measurements.

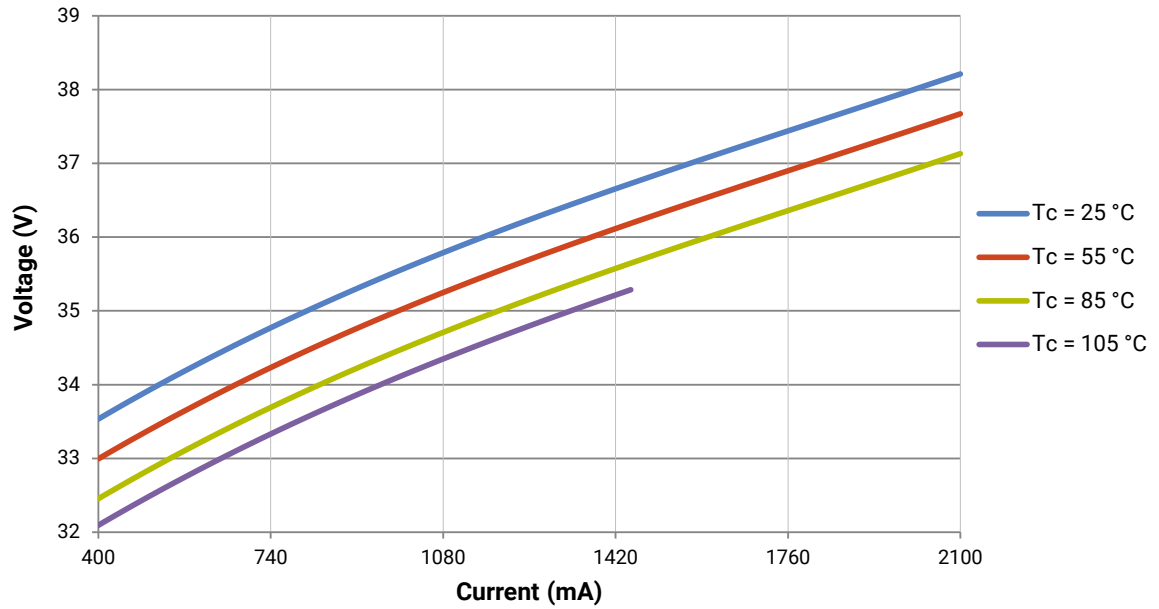

RELATIVE LUMINOUS FLUX

The relative luminous flux values provided below are the ratio of measurements of the CXB2540 LED at steady-state operation at the given conditions, divided by the flux measured during binning, which is a pulsed measurement at 1100 mA at $T_j = 85^\circ\text{C}$.

For example, at steady-state operation of $T_c = 25^\circ\text{C}$, $I_f = 740\text{ mA}$, the relative luminous flux ratio is 80% in the chart below. A CXB2540 LED that measures 5225 lm during binning will deliver 4180 lm ($5225 * 0.8$) at steady-state operation of $T_c = 25^\circ\text{C}$, $I_f = 740\text{ mA}$.

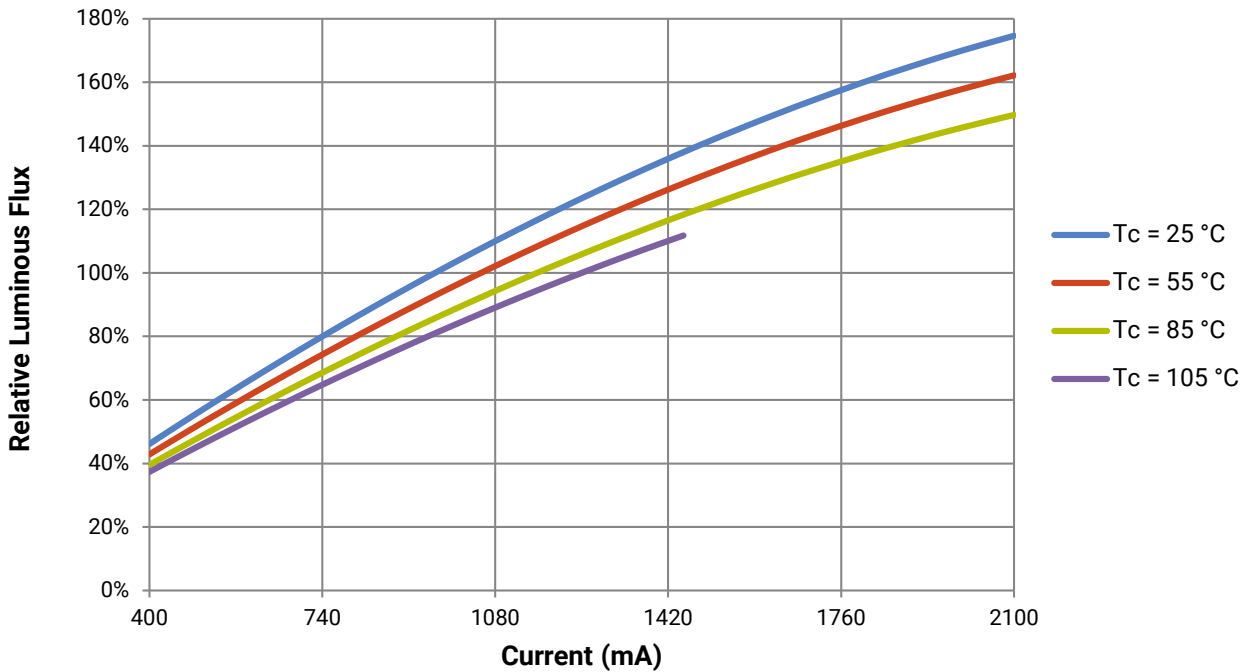

TYPICAL SPATIAL DISTRIBUTION

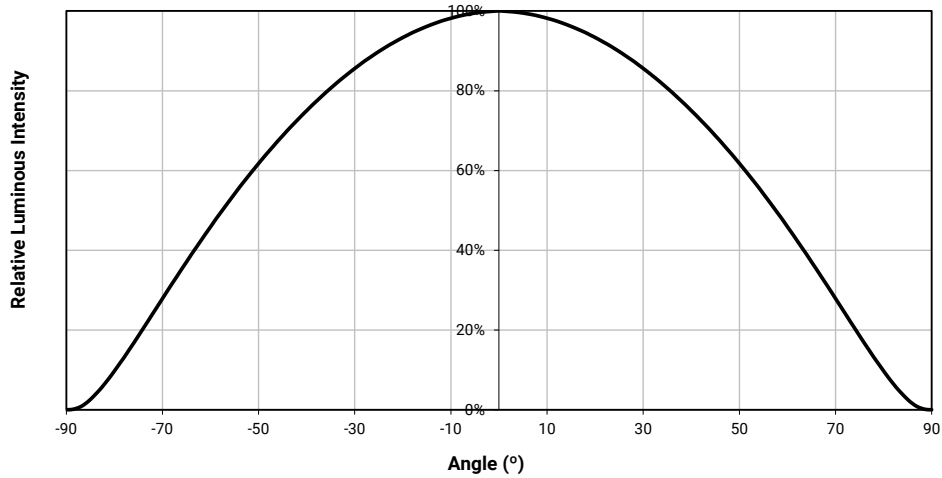

PERFORMANCE GROUPS - BRIGHTNESS ($I_F = 1100 \text{ mA}$, $T_J = 85 \text{ °C}$)

XLamp CXB2540 LEDs are tested for luminous flux and placed into one of the following bins.

Group Code	Minimum Luminous Flux	Maximum Luminous Flux
U2	3680	3955
U4	3955	4230
V2	4230	4545
V4	4545	4860
W2	4860	5225
W4	5225	5590
X2	5590	6010
X4	6010	6430

PERFORMANCE GROUPS - CHROMATICITY ($T_j = 85\text{ }^\circ\text{C}$)

XLamp CXB2540 LEDs are tested for chromaticity and placed into one of the regions defined by the following bounding coordinates.

EasyWhite Color Temperatures – 2-Step			
Code	CCT	x	y
40H	4000 K	0.3777	0.3739
		0.3797	0.3816
		0.3861	0.3855
		0.3838	0.3777
35H	3500 K	0.4022	0.3858
		0.4053	0.3942
		0.4125	0.3977
		0.4091	0.3891
30H	3000 K	0.4287	0.3975
		0.4328	0.4064
		0.4390	0.4086
		0.4347	0.3996
27H	2700 K	0.4524	0.4048
		0.4574	0.4140
		0.4633	0.4154
		0.4581	0.4062

EasyWhite Color Temperatures – 3-Step Ellipse						
Bin Code	CCT	Center Point		Major Axis	Minor Axis	Rotation Angle (°)
		x	y	a	b	
50G	5000 K	0.3447	0.3553	0.00840	0.00312	65.0
40G	4000 K	0.3818	0.3797	0.00939	0.00402	53.7
35G	3500 K	0.4073	0.3917	0.00927	0.00414	54.0
30G	3000 K	0.4338	0.4030	0.00834	0.00408	53.2
30Q	3000 K	0.4305	0.3935	0.00834	0.00408	53.2
30U	3000 K	0.4274	0.3837	0.00834	0.00408	53.2
27G	2700 K	0.4577	0.4099	0.00834	0.00420	48.5

EasyWhite Color Temperatures – 5-Step Ellipse						
Bin Code	CCT	Center Point		Major Axis	Minor Axis	Rotation Angle (°)
		x	y	a	b	
65E	6500 K	0.3123	0.3282	0.01110	0.00550	61.0
57E	5700 K	0.3287	0.3417	0.01230	0.00600	72.0
50E	5000 K	0.3447	0.3553	0.01400	0.00520	65.0
40E	4000 K	0.3818	0.3797	0.01565	0.00670	53.7

CREE'S EASYWHITE® BINS PLOTTED ON THE 1931 CIE COLOR SPACE ($T_j = 85^\circ\text{C}$)

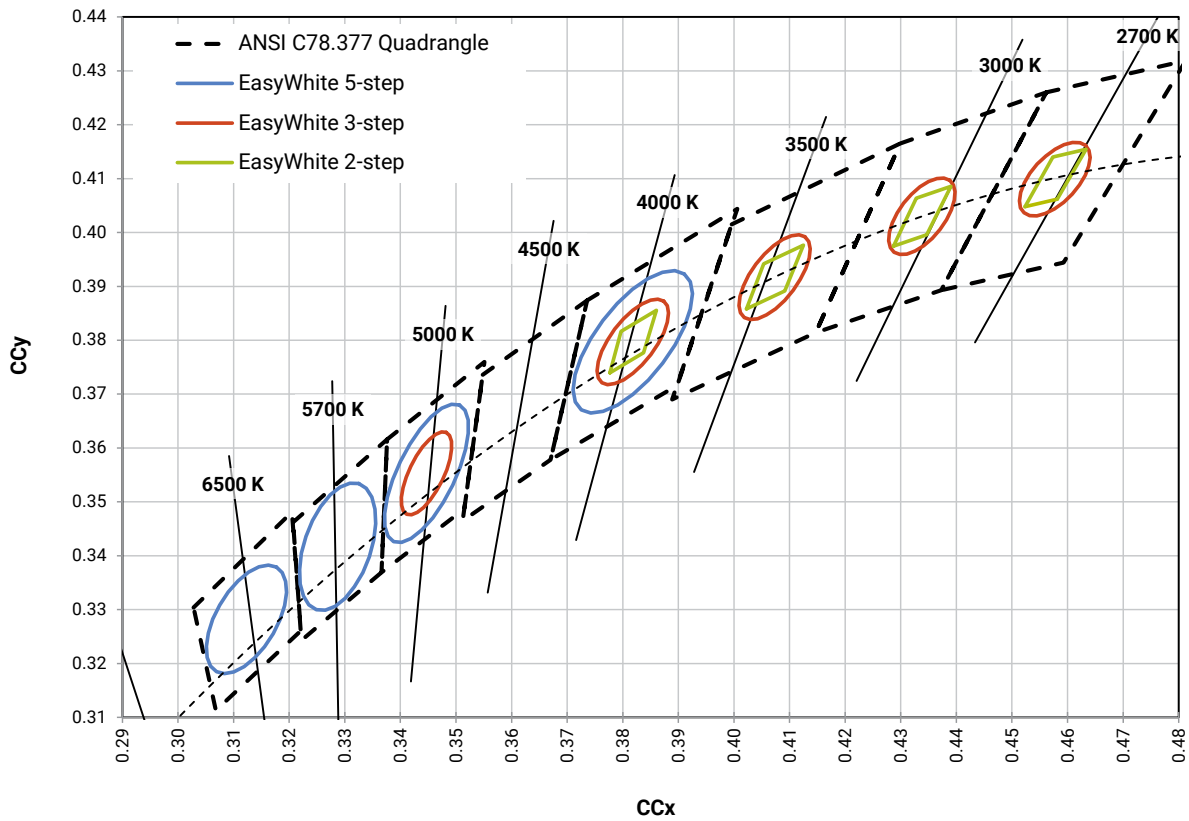

CREE EASYWHITE® BINS PLOTTED ON THE 1931 CIE COLOR SPACE ($T_j = 85^\circ\text{C}$) - CONTINUED

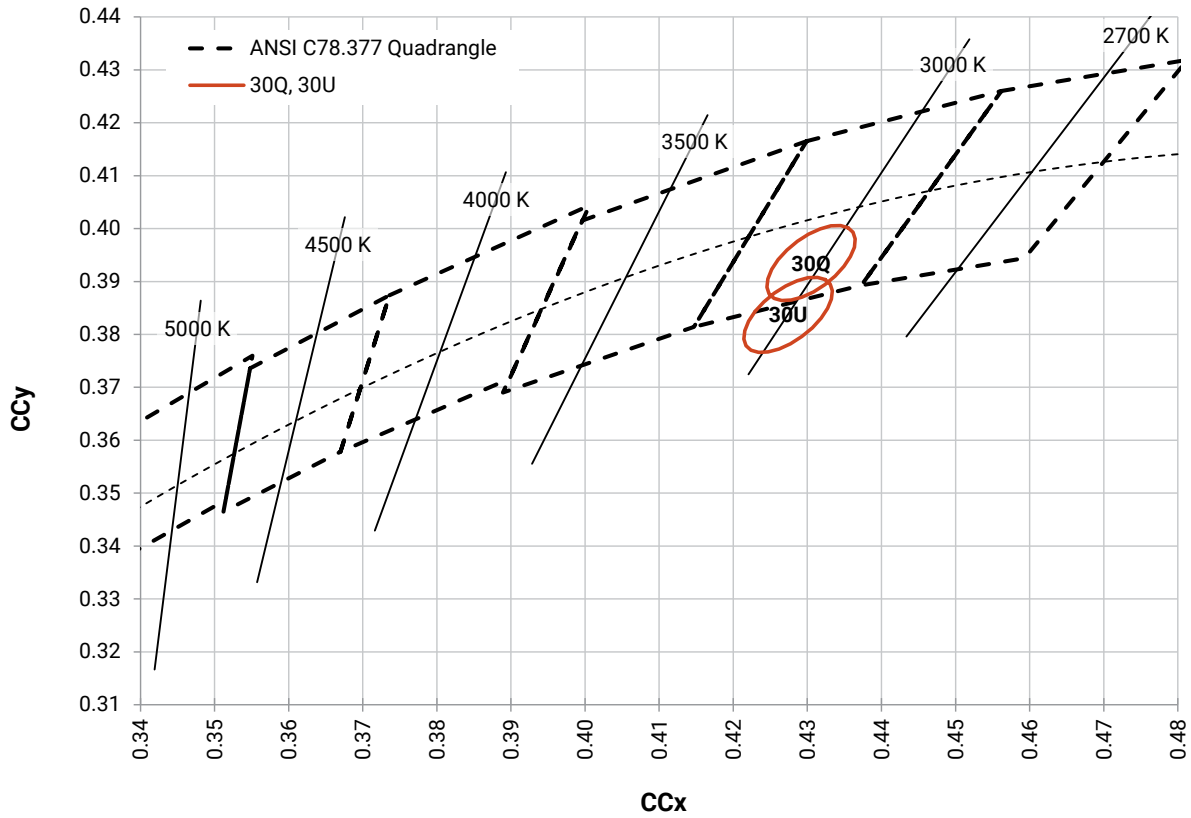

BIN AND ORDER CODE FORMATS

Bin codes and order codes are configured as follows:

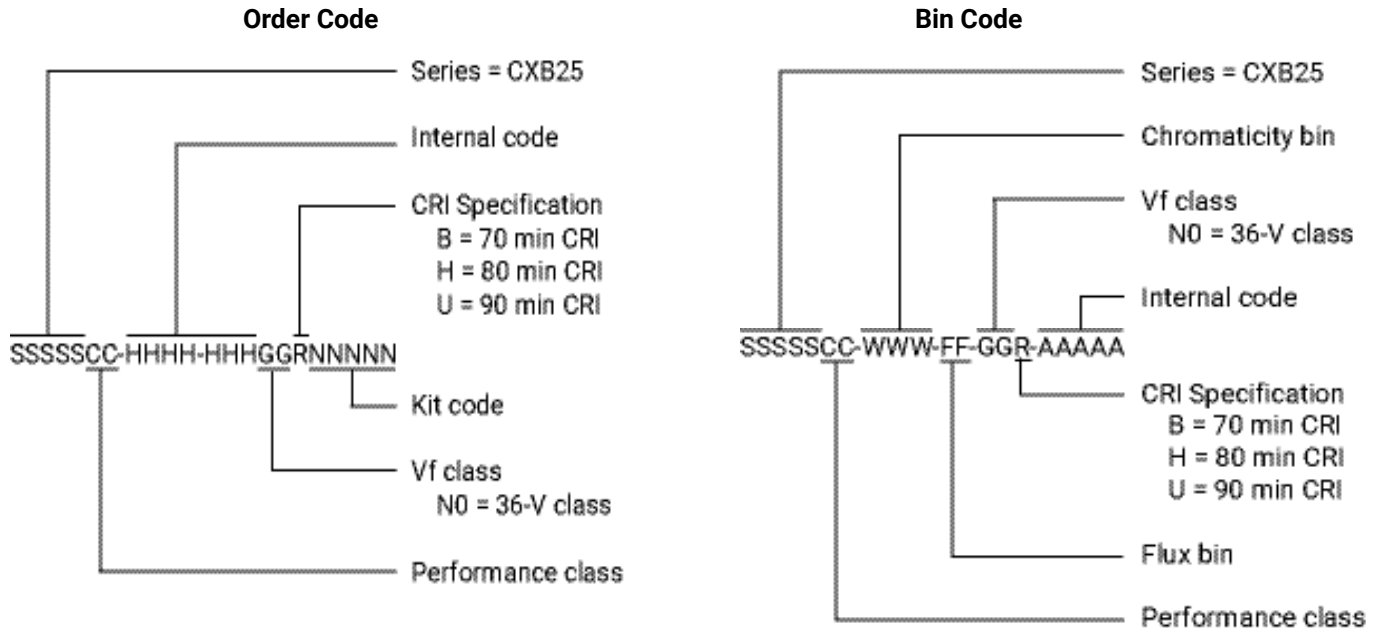

MECHANICAL DIMENSIONS

Dimensions are in mm.
 Tolerances unless otherwise specified: ± 0.13
 $\alpha^\circ \pm 1^\circ$

Meaning of B2540N
 B2540N = 36-V CXB2540

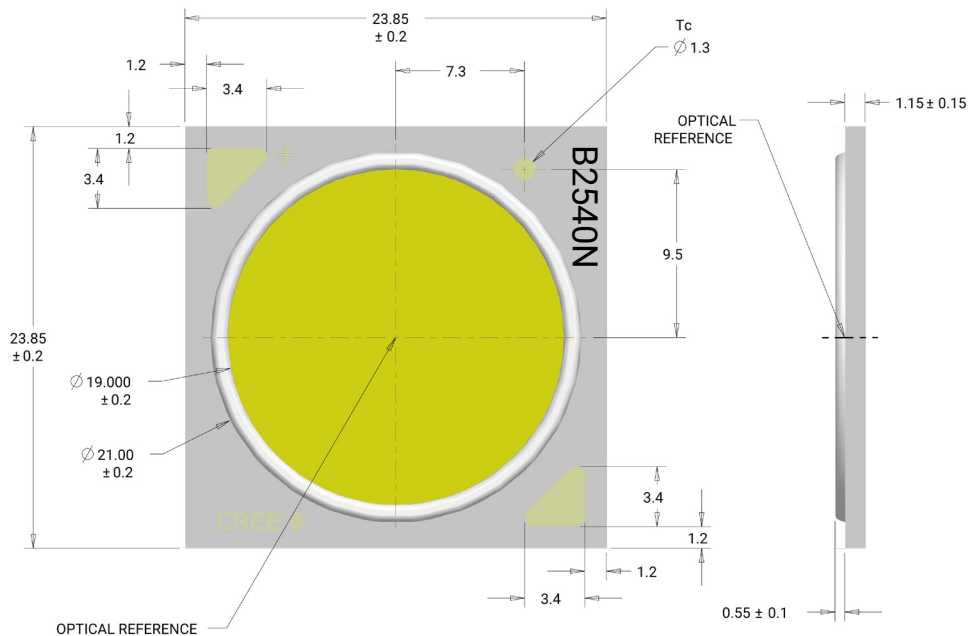

THERMAL DESIGN

The CXB family of LED arrays can include over a hundred different LED die inside one package, and thus over a hundred different junction temperatures (T_j). Cree has intentionally removed junction-temperature-based operating limits and replaced the commonplace maximum T_j calculations with maximum ratings based on forward current (I_f) and case temperature (T_c). No additional calculations are required to ensure the CXB LED is being operated within its designed limits. Please refer to page 2 for the Operating Limit specification.

There is no need to calculate for T_j inside the package, as the thermal management design process, specifically from solder point (T_{sp}) to ambient (T_a), remains identical to any other LED component. For more information on thermal management of Cree XLamp LEDs, please refer to the [Thermal Management application note](#). For CXB soldering recommendations and more information on thermal interface materials (TIM) and connection methods, please refer to the [Cree XLamp CX Family LEDs soldering and handling document](#). The [CX Family LED Design Guide](#) provides basic information on the requirements to use Cree XLamp CXB LEDs successfully in luminaire designs.

To keep the CXB2540 LED at or below the maximum rated T_c , the case to ambient temperature thermal resistance (R_{c-a}) must be at or below the maximum R_{c-a} value shown on the following graph, depending on the operating environment. The y-axis in the graph is a base 10 logarithmic scale.

As the figure at right shows, the R_{c-a} value is the sum of the thermal resistance of the TIM (R_{tim}) plus the thermal resistance of the heat sink (R_{hs}).

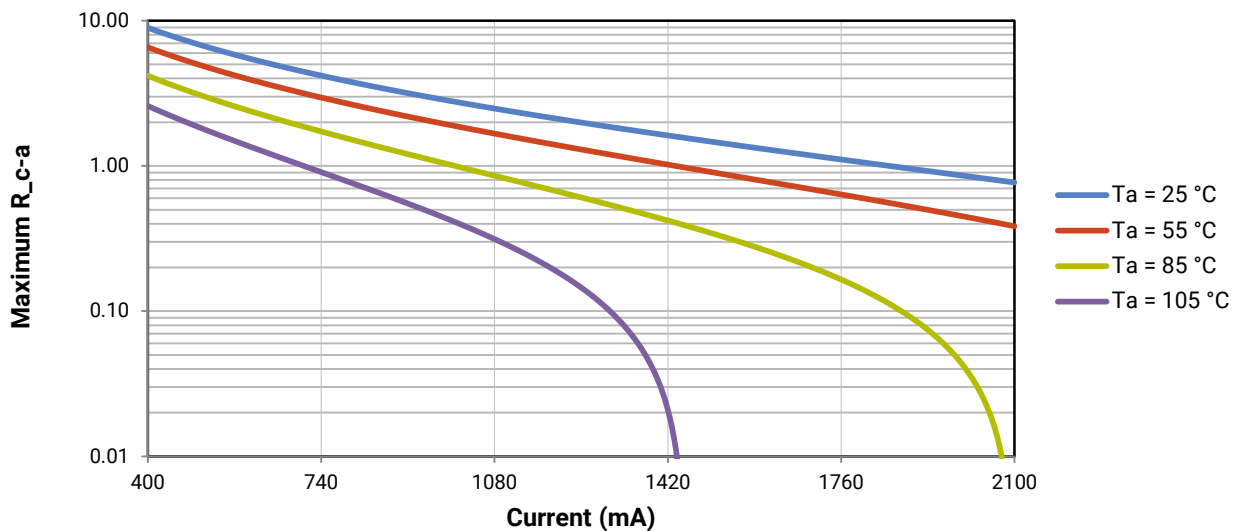
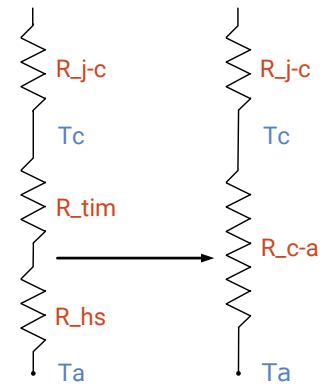

NOTES

Measurements

The luminous flux, radiant power, chromaticity, forward voltage and CRI measurements in this document are binning specifications only and solely represent product measurements as of the date of shipment. These measurements will change over time based on a number of factors that are not within Cree's control and are not intended or provided as operational specifications for the products. Calculated values are provided for informational purposes only and are not intended as specifications.

Pre-Release Qualification Testing

Please read the [LED Reliability Overview](#) for details of the qualification process Cree applies to ensure long-term reliability for XLamp LEDs and details of Cree's pre-release qualification testing for XLamp LEDs.

Lumen Maintenance

Cree now uses standardized IES LM-80-08 and TM-21-11 methods for collecting long-term data and extrapolating LED lumen maintenance. For information on the specific LM-80 data sets available for this LED, refer to the public [LM-80 results document](#).

Please read the [Long-Term Lumen Maintenance application note](#) for more details on Cree's lumen maintenance testing and forecasting. Please read the [Thermal Management application note](#) for details on how thermal design, ambient temperature, and drive current affect the LED junction temperature.

RoHS Compliance

The levels of RoHS restricted materials in this product are below the maximum concentration values (also referred to as the threshold limits) permitted for such substances, or are used in an exempted application, in accordance with EU Directive 2011/65/EC (RoHS2), as implemented January 2, 2013. RoHS Declarations for this product can be obtained from your Cree representative or from the Product Documentation sections of www.cree.com.

REACH Compliance

REACH substances of very high concern (SVHCs) information is available for this product. Since the European Chemical Agency (ECHA) has published notice of their intent to frequently revise the SVHC listing for the foreseeable future, please contact a Cree representative to insure you get the most up-to-date REACH Declaration. REACH banned substance information (REACH Article 67) is also available upon request.

UL® Recognized Component

Level 4 enclosure consideration. The LED package or a portion thereof has been investigated as a fire and electrical enclosure per ANSI/UL 8750.

Vision Advisory

WARNING: Do not look at an exposed lamp in operation. Eye injury can result. For more information about LEDs and eye safety, please refer to the [LED Eye Safety application note](#).

PACKAGING

Cree CXB2540 LEDs are packaged in trays of 20. Five trays are sealed in an anti-static bag and placed inside a carton, for a total of 100 LEDs per carton. Each carton contains 100 LEDs from the same performance bin.

Dimensions are in inches.
Tolerances: $\pm .13$
 $x^\circ \pm 1^\circ$

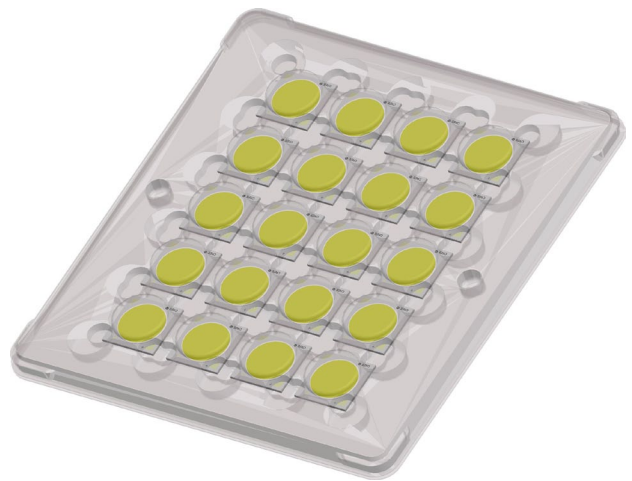
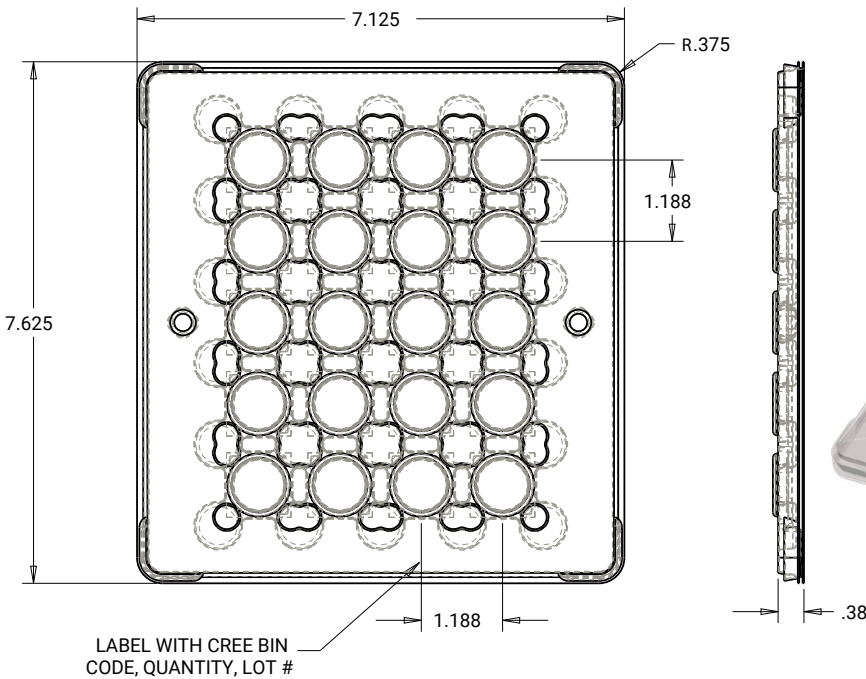

PATENT LABEL IS LOCATED ON UNDERSIDE OF CARTON

